

Running outlet BI-SYSTEM for gutter profile \varnothing 125

BI-SYSTEM

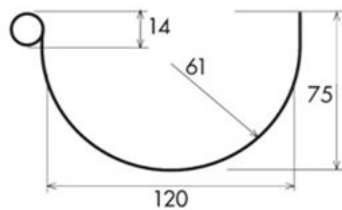

GSN125N

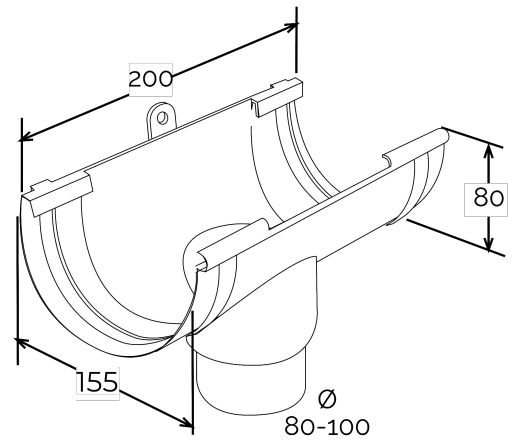

Section GRN125

Item	Colour	length mm	width mm	height + bracket mm	Weight g	Matched gutter profile
GSN125A	anthracite	155	200	168	210	GRNA125C
GSN125B	white	155	200	168	210	GRN125B - GRN125BC
GSN125M	brown	155	200	168	210	GRN125M - GRN125MC
GSN125N	grey	155	200	168	210	GRN125N
GSN125O	red brown	155	200	168	210	GRNO125C
GSN125S	sand	155	200	168	210	GRN125S

Material: PVC-U

Features:

The BI-SYSTEM joint can be used whether glued or fitted with gasket.
GLUING: The joint must be glued to the gutter by inserting it into the specific sockets. Clean the surfaces, then use PVC sealant glue (COFxxx).
FITTING: Clean the surfaces, then place the adhesive gasket (GU20) into its specific slot. Insert the gutter into the specific sockets.

