

Drain well box



Patented models



PZS30

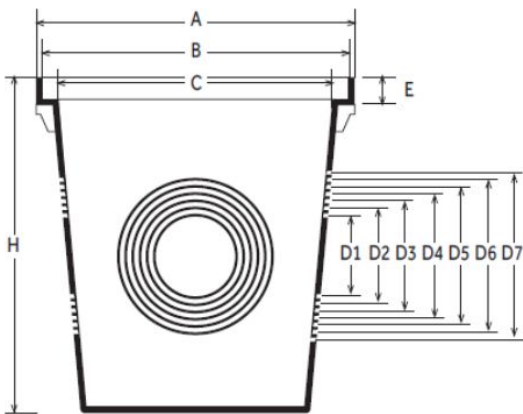

Description	U/M	Item		
		PZS20	PZS30	PZS45
Weight	gr	460	1160	2960
A	mm	197	293	444
B	mm	189	286	436
C	mm	158	258	400
E	mm	200	300	397
H	mm	24	25	29
D1	mm	50	80	90
D2	mm	63	90	100
D3	mm	75	100	125
D4	mm	82	110	160
D5	mm	90	125	200
D6	mm	100	140	250
D7	mm	110	-	-

Material: Mineral filled reinforced polypropylene

Colour: Light grey

Features: The drain wells are used to collect rainwater from streets, squares, garages, cellars, underground rooms, or more generally wherever the collection of liquids is necessary.

- The predisposition for the connection of the pipes, by inserting the GUS20/GUS30/GUS45 gasket, is on all 4 sides. The pre-fracture lines are easily broken with a tip and hammer.
- The Simplex series wells can be stacked together, allowing for minimum space requirement during storage and transport.



FIRST PLAST S.r.l.
 Località Isola Grande
 17041 ALTARE (SV) - ITALIA
 Tel. +39 019 58511
 Email: export.first@firstcor.com

