

Drain well box

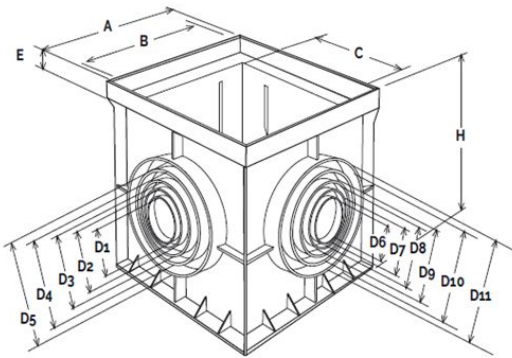

PZN20
PZN30



PZ40
PZ55

Description	U/M	Item			
		PZN20	PZN30	PZ40	PZ55
Weight	g	550	1250	3650	6570
A	mm	196	297	398	548
B	mm	190	286	386	537
C	mm	158	253	353	503
E	mm	20	22	25	35
H	mm	200	300	400	448
D1	mm	63	80	100	125
D2	mm	80	100	125	160
D3	mm	100	125	160	200
D4	mm	110	-	200	250
D5	mm	-	-	250	315
D6	mm	63	80	100	125
D7	mm	80	100	110	160
D8	mm	100	125	125	200
D9	mm	110	-	160	250
D10	mm	-	-	200	315
D11	mm	-	-	250	-

Material: Mineral filled reinforced polypropylene

Colour: Light grey

Features:

- The well boxes are used to collect rainwater from streets, squares, garages, cellars, underground rooms, or more generally wherever the collection of liquids is necessary.
- The predisposition for the connection of the pipes is on all 4 sides.
- The pre-fracture lines are easily breakable with a hammer and bit.
- In the PZN20 and PZN30 wells the female inlet diameters (D1/D2/D3/D4) are at a higher level than the male outlet diameters (D6/D7/D8/D9).
- In the PZ40 and PZ55 wells all the grafts are female and are located at the same level on all sides.

