

Completion range building fittings - expansion joint with O-Ring -

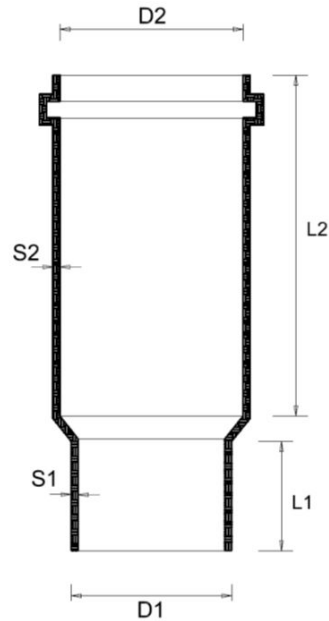

MDS100



REFERENCE REGULATIONS: UNI EN 1329-1:2021

Item	D1 (M) mm	D2 (F) mm	L1 (M) mm	L2 (F) mm	S1 (M) mm	S2 (F) mm	Weight g	Ø external mm	TOTAL H. mm
MDS080	80,0	80,5	66	168	3,1	4,1	362	98	252
MDS100	100,0	100,5	63	204	2,7	3,8	420	118	272
MDS125	125,0	125,7	79	190	3,4	3,0	518	146	278

Material: PVC-U

Colour: Orange RAL 2008

Features: The range of solvent cement fittings produced by First Plast, is made of U-PVC in compliance with UNI EN1329-1:2021 standards, relating to high and low temperature drainage for building indoor applications. The expansion joint is composed of two pre-assembled elements: a sleeve and a black rubber gasket

