

Extension for drain well boxes

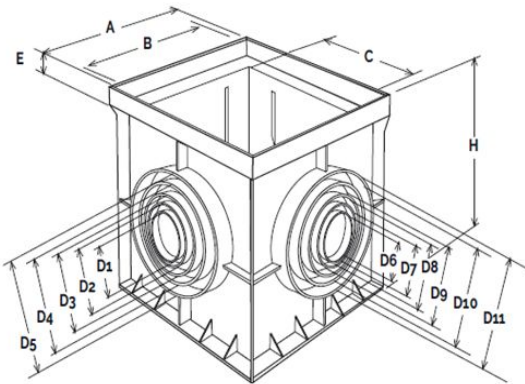

APZN20
APZN30



APZ40
APZ55

Description	U/M	Item			
		APZN20	APZN30	APZ40	APZ55
Weight	g	450	1170	3180	5000
A	mm	196	297	398	548
B	mm	190	286	386	537
C	mm	158	253	353	503
E	mm	20	22	25	35
H	mm	200	300	400	448
D1	mm	63	80	100	125
D2	mm	80	100	125	160
D3	mm	100	125	160	200
D4	mm	110	-	200	250
D5	mm	-	-	250	315
D6	mm	63	80	100	125
D7	mm	80	100	110	160
D8	mm	100	125	125	200
D9	mm	110	-	160	250
D10	mm	-	-	200	315
D11	mm	-	-	250	-

Material:

Mineral filled reinforced polypropylene

Colour:

Light grey

Features:

Universal extensions are used when the pipe is at a greater depth than the well, which has the function of collecting rainwater or more generally wherever the collection of liquids is necessary.

- The predisposition for the connection of the pipes is on all 4 sides.
- The pre-fracture lines are easily broken with a hammer and bit.
- In the APZN20 and APZN30/APZNE30 extensions the female inlet diameters (D1/D2/D3/D4) are at a higher level than the male outlet ones (D6/D7/D8/D9).
- In the APZ40 and APZ55 extensions all the connections are female and are located at the same height on all sides.

