

Exterior angle BI-SYSTEM for gutter profile 100x110

BI-SYSTEM

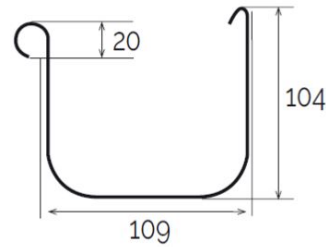

AEQM

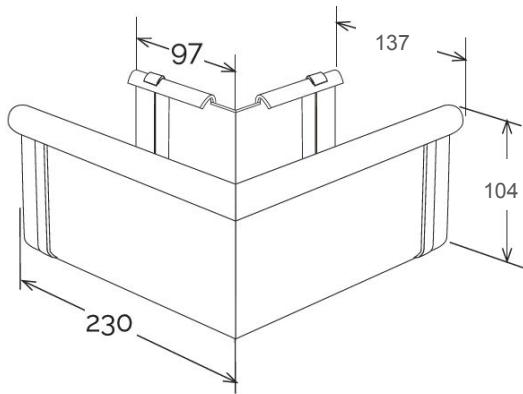

Section GRQ

Item	Colour	length mm	width mm	height mm	Weight g	Item	IIP compliance UNI EN 607:2023
AEQGN	grey	230	230	115	390	GRQGN	✓
AEQM	brown	230	230	115	390	GRQM	✓

Material: PVC-U

Features:

The BI-SYSTEM joint can be used whether glued or fitted with gasket.

GLUING: The joint must be glued to the gutter by inserting it into the specific sockets. Clean the surfaces, then use PVC sealant glue (COFxxx).

FITTING: Clean the surfaces, then place the adhesive gasket (GU27) into its specific slot. Insert the gutter into the specific sockets.

