

Sifone Firenze con ispezione

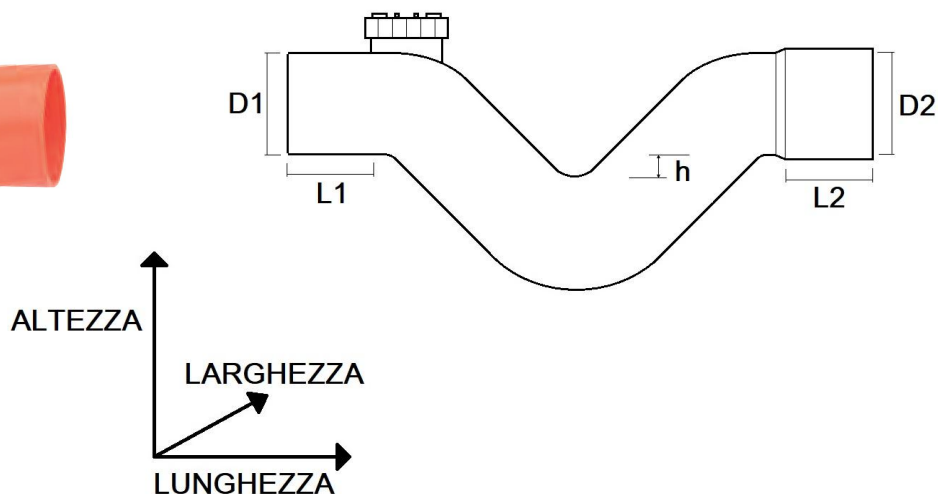

SFS100



| Codice | D1 (M) mm | D2 (F) mm | L1 (M) mm | L2 (F) mm | h battente mm | LUNGH mm | LARGH mm | ALT mm | PESO g |
|---------------|--------------|--------------|--------------|--------------|---------------------|-------------|-------------|-----------|-----------|
| SFS063 | 63,0 | 63,4 | 50 | 40 | 18 | 338 | 70 | 193 | 400 |
| SFS080 | 80,0 | 80,5 | 55 | 49 | 16 | 380 | 87 | 230 | 500 |
| SFS082 | 82,0 | 82,5 | 53 | 56 | 16 | 420 | 89 | 250 | 700 |
| SFS100 | 100,0 | 100,5 | 63 | 50 | 15 | 448 | 107 | 294 | 1100 |
| SFS125 | 125,0 | 125,6 | 69 | 56 | 36 | 534 | 132 | 363 | 1700 |
| SFS140 | 140,0 | 140,6 | 83 | 74 | 19 | 580 | 147 | 300 | 1700 |
| SFS160 | 160,0 | 160,6 | 85 | 78 | 18 | 650 | 167 | 370 | 2200 |
| SFS200 | 200,0 | 200,7 | 116 | 101 | 13 | 780 | 207 | 460 | 3700 |

Materiale: PVC-U

Colore: Arancio Tipo RAL 2008

Caratteristiche: Sifone ottenuto mediante saldatura di due curve a 45° ed una a 87° e l'applicazione di tappo filettato per ispezione e chiusura con O-Ring in EPDM nera

